

Displaying 2 transducer readings simultaneously



Transducer reading (left) and graphing (right)



Home menu for 2 separate windows

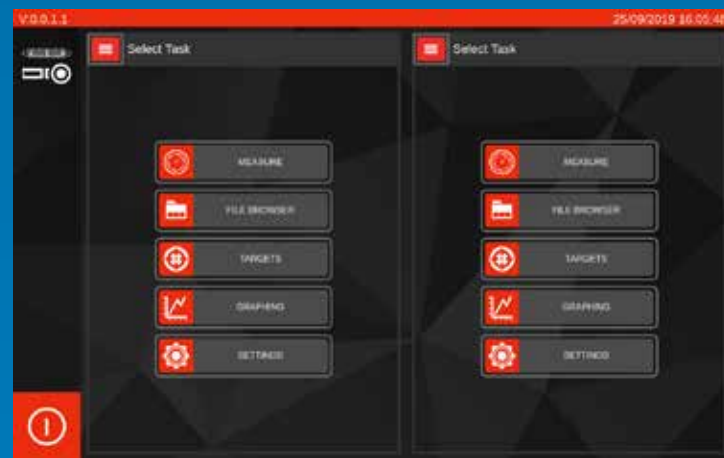

Readings pane (left) transducer measurement (right)

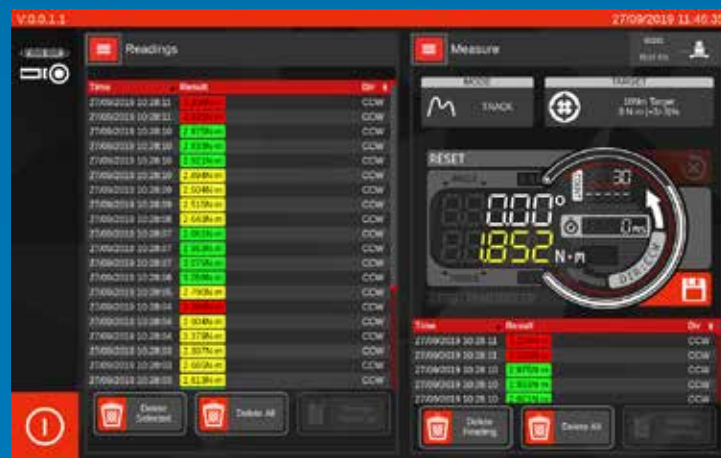

Transducer measurement (left)
Mode configuration (right)



Storage destination (left)
File browser (right)



GLOBAL SERVICE

Norbar is the only torque equipment manufacturer capable of offering tool and instrument calibration services to the original factory standard on four continents.

Accredited laboratories in Australia, USA, Singapore, China and India operate the same equipment and procedures as the UKAS accredited laboratory within our headquarters in the UK.



NORBAR TORQUE TOOLS LTD
Wildmere Road, Banbury, Oxfordshire, OX16 3JU
UNITED KINGDOM
Tel + 44 (0)1295 753600
Email sales@norbar.com



NORBAR TORQUE TOOLS
45-47 Raglan Avenue, Edwardstown
SA 5039
AUSTRALIA
Tel + 61 (0)8 8292 9777
Email norbar@norbar.com.au



NORBAR TORQUE TOOLS INC
36400 Biltmore Place, Willoughby
Ohio 44094
USA
Tel + 1 866 667 2272
Email inquiry@norbar.us



NORBAR TORQUE TOOLS
c/o Snap-on Tools Singapore PTE LTD
25 Tagore Lane #01-02
SINGAPORE 787 602
Tel +65 6841 1371
Email enquiries@norbar.sg



NORBAR TORQUE TOOLS (SHANGHAI) LTD
91 Building- 7F, No. 1122, North Qinzhou Road,
Xuhui District, Shanghai
CHINA 201103
Tel + 86 21 6145 0368
Email sales@norbar.com.cn



NORBAR TORQUE TOOLS INDIA PVT. LTD
Plot No A – 168 Khairne Industrial Area
Thane Belapur Road
Mahape Navi Mumbai – 400 709
INDIA
Tel + 91 22 2778 8480
Email enquiry@norbar.in

www.norbar.com



NORBAR PRODUCT PORTFOLIO



Torque Screwdrivers



Torque Wrenches



Electronic Torque Wrenches



Manual Torque Multipliers



Pneumatic Torque Tools



Electronic Torque Tools



Battery Torque Tools



Torque Measurement Instruments



Torque Transducers



Calibration Services

NEW FEATURES

T-BOX™ 2

COMPREHENSIVE, INTELLIGENT TORQUE DATA ANALYSER



Distributed by

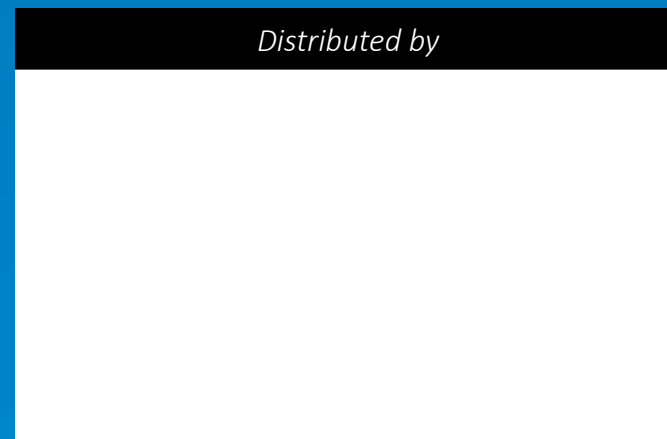

The T-Box™ 2 utilises its powerful processor to provide a seamless and complete torque data collection package. This is capable of tool calibrations, data logging, simultaneous transducer connections and archiving to your PC.

Features a 10.1" multi-touch screen display with on-screen graphic icons for simple and easy tool navigation and selection

User configurable to allow a selection of torque, torque and angle, rate targets and the ability to set thresholds



Two task windows allows simultaneous working! Measure against a target while graphing the cycle, take readings from two transducers simultaneously, capture two different graphs at the same time or manage and review readings as they are captured

Ability to network via USB Adapter

2 USB Ports



KEY FEATURES

- Accuracy of ±0.05% of reading (±0.1% when below 10% of transducer capacity)
- System accuracy with a typical Norbar transducer, ±0.5% from 20% of transducer capacity
- Includes 6 modes for torque tool measurement: Track, Click, Dial & Electronic, Stall, Screwdriver and Hydraulic
- Can export readings and graphs to CSV and JSON format allowing for 3rd party software integration
- File browser/manager for internal storage and USB management giving the user greater ease and flexibility in managing multiple files and folders
- Fast CPU frequency up to 2.3 GHz
- 2 transducer ports gives you the ability to perform 2 tasks simultaneously e.g. graphing & measuring
- Large capacity memory of 120 GB SSD storage
- The T-Box™ 2 can capture graphs up to 325 Hz, offering the ability to analyse fast moving transients
- 4GB RAM allows for smooth and seamless operation
- Ability to predefine multiple targets
- Features hardened and impact resistant glass helping to prevent chips and scratches appearing on the screen's surface
- A standard T-Box™ 2 is supplied with a UKAS accredited bi-directional calibration certificate recording each input as an independent channel

Norbar's AnB modules are a key differentiator between the T-Box™ 2 and other torque measuring instruments, including others from Norbar. While they may have the appearance of regular transducer inputs, they are actually distinct computing modules which operate independently and contain their own states and settings. For instance, when we talk about mode settings for T-Box™ 2, we do so in the context of each AnB module, as it is the module which is set in that mode and uses those settings. The T-Box™ 2 contains two AnB modules which are displayed separately using a split screen. Where this really comes into its own is when the activity on one AnB needs to be compared, graphed for example, against the activity on the other AnB. A good application for this would be the calibration of hydraulic torque wrenches where one AnB is configured to read a torque transducer and the other is configured to read a pressure transducer, allowing the user to build up a torque versus pressure graph using one instrument.

2 Transducer Ports

2 independently configurable ancillary ports

1 RS-232 Serial Port

Continuous output of up to 100 readings per second per port via RS-232 or USB virtual serial device



Bench stand supplied as standard with an adjustable viewing angle

New software version 1.0.2.X available

- Ability to set up new graph pre-sets and defaults, saving the user time
- New graphing settings allows the user to set a maximum graph duration to stop data capture after a designated time
- Can link targets with the ability to delete previously captured result
- Intelligent target file history memorises the last-used files for individual AnB modules improving convenience when working with two transducers with different sets of targets at once
- Ability to enable or disable implicit AnB selection allowing for greater control when setting or clearing targets in AnB modules
- Users can now toggle serial data output on/off per AnB allowing the ability to suppress output from one AnB and leaving only the data stream from the AnB of interest
- Progressive Reset lets you sweep through a series of Linked Targets for the purpose of rapidly calibrating hydraulic wrenches or gearboxes (peak-type modes only)
- Broadcast Capture Triggers lets you trigger capture of a reading on the neighbouring AnB when a reading capture is made on the target (peak-type and click modes only; peak-type modes require Progressive Reset to be enabled)
- Combining Progressive Reset and Broadcast Capture Triggers with Linked Targets to capture hydraulic wrench torque at a series of desirable pressure levels for rapid hydraulic wrench calibration. This approach can dramatically reduce calibration times (for instance, from several minutes to under 1 minute)
- Capture large numbers of readings with more fluidity than ever before thanks to performance optimisations in the user interface
- Simplified update procedure allowing for updates within T-Box™ 2 User Interface without the requirement of a keyboard

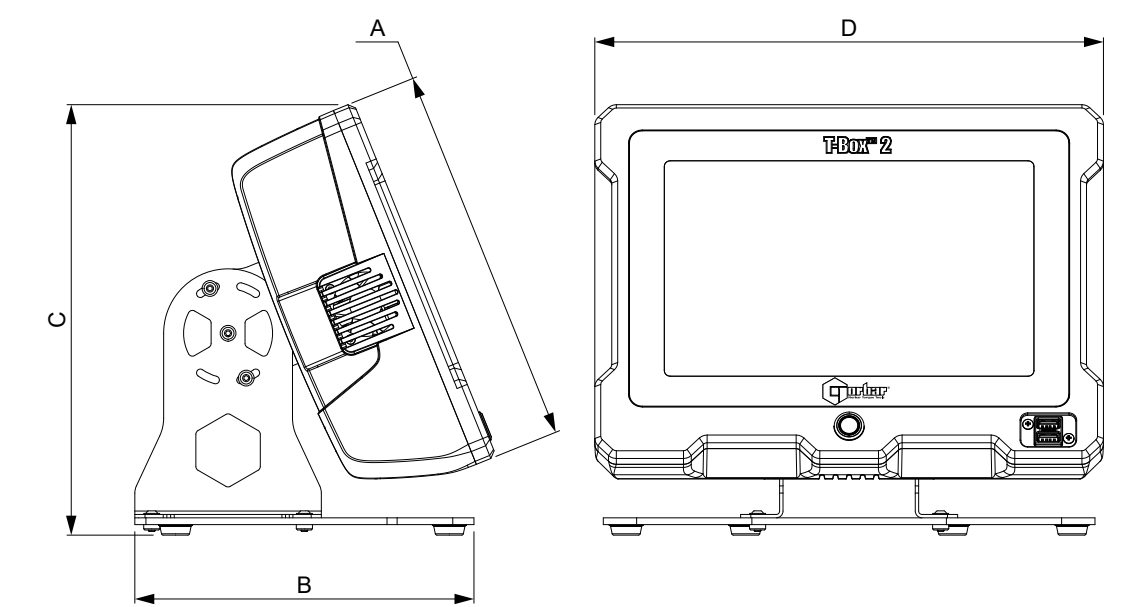

Rear panel features 100 mm x 100 mm VESA mounting holes, allowing for easy wall mounting or the use of third party stands / arms

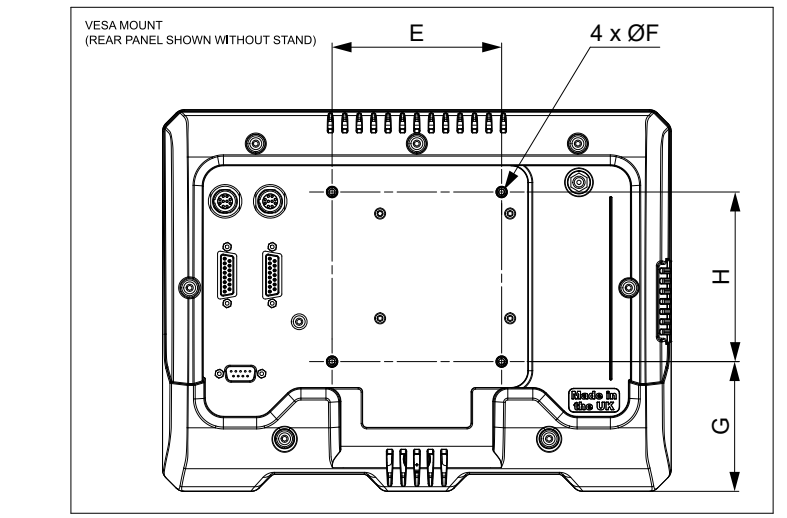

MODEL	T-Box 2	
Part Number	43542	
Tool Weight (kg)	5.2	
Dimensions (mm)	A	225
	B	200
	C	254
	D	300
	E	100
	ØF	M4
	G	76
H	100	